

# FLUID ENERGY

**PROCESSING AND EQUIPMENT COMPANY**

The World Leader in Powder Processing Solutions

## ROTO-JET

Size Reduction Systems



## MICRO-JET

Size Reduction Systems



## JET-O-MIZER

Size Reduction Systems



## THERMAJET

Flash Drying Systems



## POWDER PROCESSING

Ultra-Fine to Coarse Powder Processing

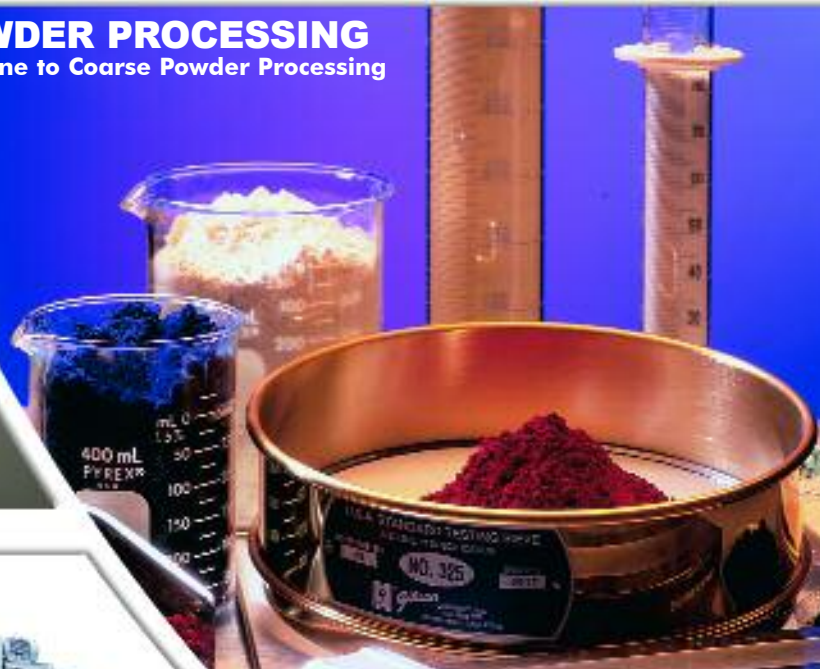

## ROTO-SIZER

Classification Systems



The World Leader in  
**Powder Processing**  
Solutions



## EQUIPMENT DIVISION

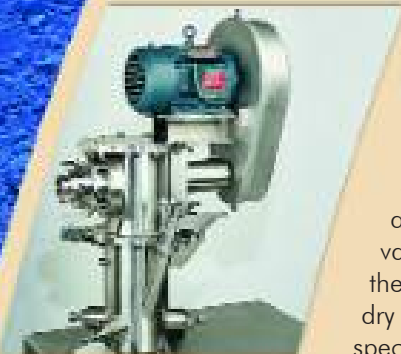

### ROTO-JET Size Reduction Systems

The Roto-Jet is a fluid-bed jet mill which features opposed grinding nozzles and a dynamic classifier. Opposed nozzles reduce abrasion while the classifier rotor operates at variable speeds to provide ultimate control of the particle size distribution. Capable of grinding dry powders to 0.5-40 micron averages with specific top size and/or bottom size requirements.

#### Typical Roto-Jet Particle Size Distribution

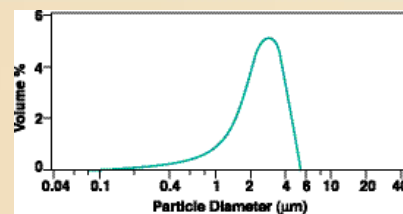

### MICRO-JET Size Reduction Systems

The Micro-Jet is a horizontally oriented jet mill with tangential grinding nozzles located around the peripheral wall of the grinding chamber. Capable of grinding dry powders to 0.5-45 micron averages, this mill generates a maximum amount of "fines" resulting in high surface areas. Grinding and static classification both occur with a single, cylindrical chamber.

#### Typical Micro-Jet Particle Size Distribution

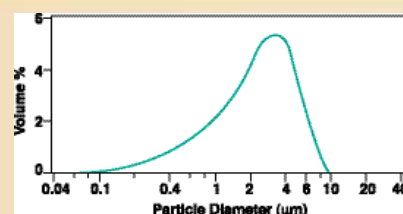

### JET-O-MIZER Size Reduction Systems

The Jet-O-Mizer is a vertically oriented jet mill with tangential grinding nozzles located at the bottom and static classification occurring at the top. Capable of grinding dry powders to 1-50 micron averages, this mill produces a narrow particle size distribution, consumes less energy and is easy to feed with a wide variety of materials.

#### Typical Jet-O-Mizer Particle Size Distribution

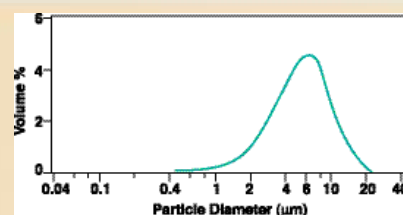

### THERMAJET Flash Drying Systems

The ThermoJet is a recirculating loop flash dryer utilizing a combination of temperature and pressure to deagglomerate and dry heat-sensitive materials. The system produces dry, discrete particles from a "wet cake" or "slurry" feed. Recirculating gases and deagglomeration ensure maximum thermal efficiency while achieving moisture specifications at less than 0.1%.

#### Representative ThermoJet Capabilities

Inlet Temp. (°F)  
200°F — 1200°F

Raw Feed Moisture (%H<sub>2</sub>O)  
1% — 80%

Evaporative Rates (LB/HR H<sub>2</sub>O)  
20 (LB/HR) — 1000 (LB/HR)



### ROTO-SIZER Classification Systems

The Roto-Sizer is a forced-vortex air classifier designed to provide precise classification of fine powders. A specially engineered classification chamber and classifying rotor produce "cut" sizes down to 3 microns and produce yields of up to 92%. The classifier can operate as a separate system or it can be installed in-line with a mechanical or jet-milling operation.

#### Typical Roto-Sizer Particle Size Distribution

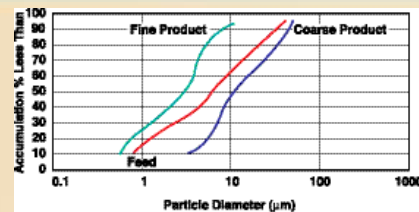

### **ROTO-JET Features:**

- Variable speed classifier rotor for precise classification
- Opposed grinding nozzles
- Top sizes as fine as d90 of 1 micron
- Abrasive resistant classifier rotor
- Complete manufacturing and parts supplied in the USA
- Engineering and testing services located in Pennsylvania

### **Applications:**

- Toners
- Fluoropolymers
- Ceramics
- Pigments
- Precious Metals
- Carbides

### **MICRO-JET Features:**

- *Sanitary* designs for access to gas and product contact areas
- Replaceable grinding nozzles and liners
- Specialized liners for abrasive or sticky materials
- Simple design ensures rapid disassembly for easy cleaning
- Models from 1/2 to 6,000 lbs. per hour

### **Applications:**

- Pharmaceuticals
- Pigments
- Cosmetics
- Ceramics
- Polymers

### **JET-O-MIZER Features:**

- *Sanitary* designs for access to gas and product contact areas
- No blow back, easy feed operation
- Replaceable grinding nozzles and liners
- Combined operations grinding / blending, grinding / coating
- Largest range of throughput with models for 1 gram batches (or rates up to 10,000 lbs. per hour)

### **Applications:**

- Pharmaceuticals
- Agricultural Products
- Propellants
- Minerals
- Pigments

### **THERMAJET Features:**

- Simultaneous deagglomeration and drying to produce discrete particles
- Processes heat-sensitive products without thermal degradation
- Increased surface area ensures the most efficient heat transfer
- Low-maintenance and compact design
- Inlet temperatures from 200 – 1300°F
- Calcining application occurring at less than 1300°F

### **Applications:**

- Polymers
- Pigments
- Pharmaceuticals
- Ceramics
- Sludges
- Minerals

### **ROTO-SIZER Features:**

- Top size “cuts” as fine as 3 microns
- Removal of “fines” or “coarse particles”
- Variable-speed classifier rotor
- Abrasion-resistant rotor designs
- Product yields in excess of 92%
- PLC or PC-based controls

### **Applications:**

- Pharmaceuticals
- Minerals
- Pigments
- Ceramics
- Agricultural Products
- Polymers

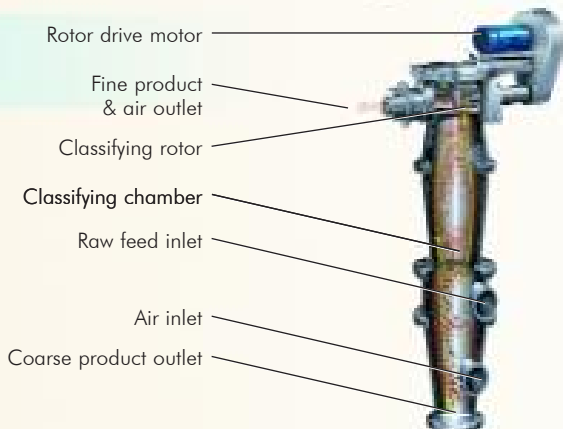
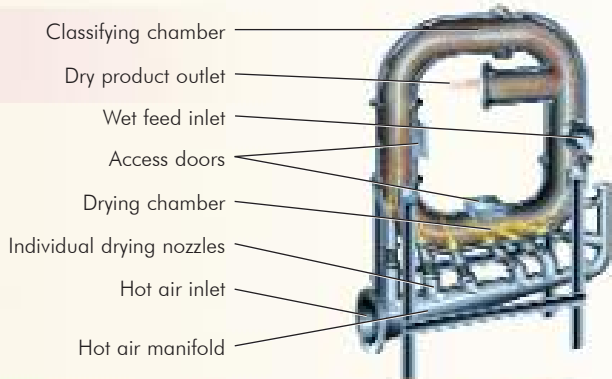
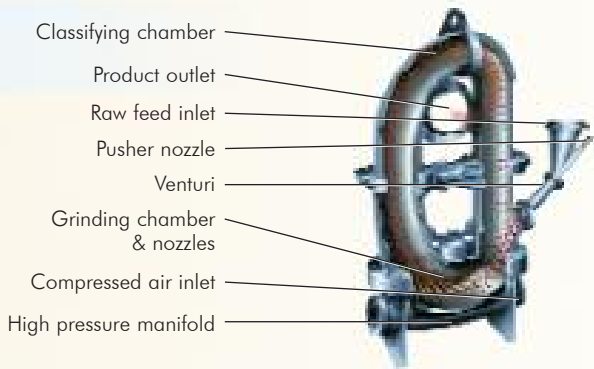
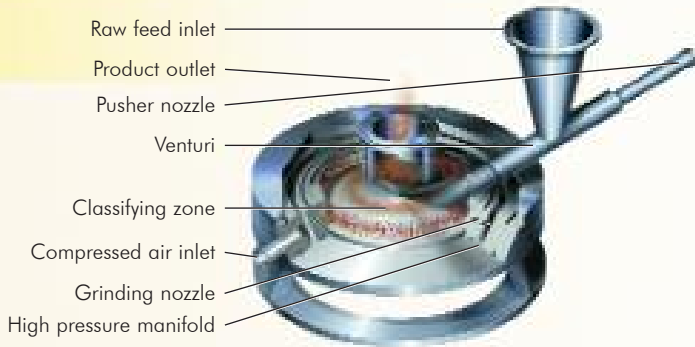
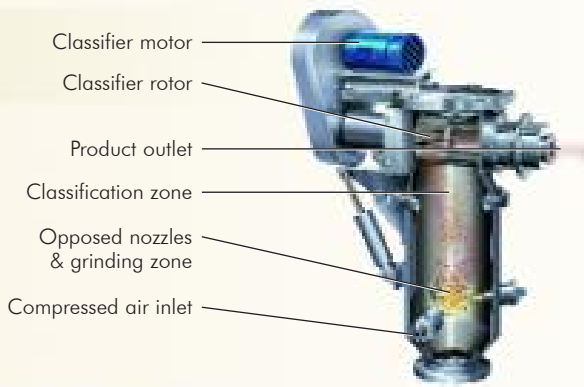

### TYPICAL ROTO-JET SYSTEM

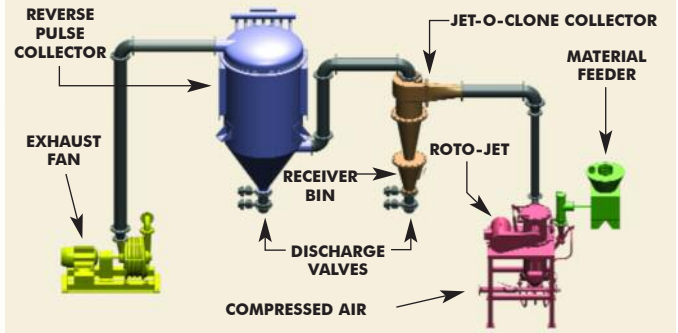

### TYPICAL MICRO-JET SYSTEM

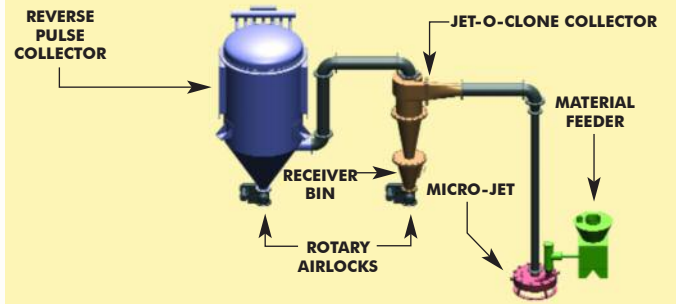

### TYPICAL JET-O-MIZER SYSTEM

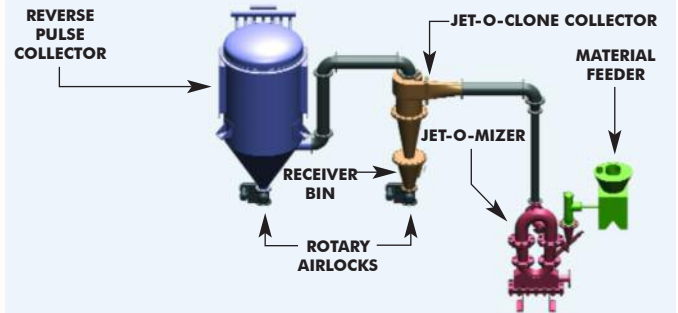

### TYPICAL THERMAJET SYSTEM

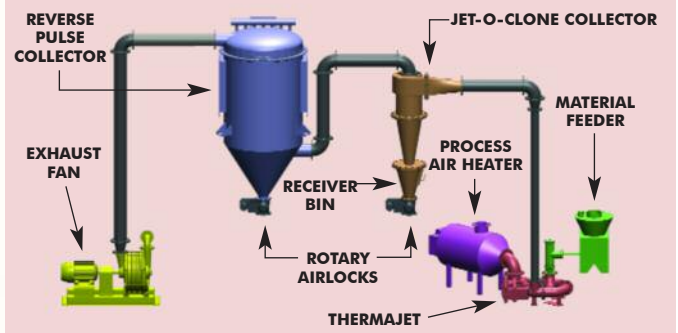

### TYPICAL ROTO-SIZER SYSTEM

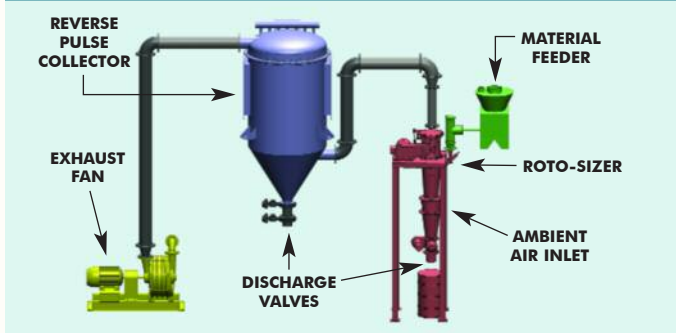

# POWDER PROCESSING DIVISION

## Ultra-Fine Grinding Services

### ROTO-JET

For customers with specific top size and/or bottom size requirements, we can grind dry powders to 0.5-40-micron averages with our Roto-Jet fluid-bed jet mill. With its variable-speed classifier rotor, this system provides ultimate control of particle size distribution.

## Ultra-Fine Grinding Services

### MICRO-JET

Capable of grinding dry powders to 0.5-45-micron averages, our Micro-Jet horizontally oriented jet mill generates a maximum amount of "fines," for customers who require high surface areas for their fine powder applications.

## Ultra-Fine Grinding Services

### JET-O-MIZER

For applications that require a narrow particle size distribution, our Jet-O-Mizer can grind a wide variety of dry powders to 1-50 micron averages. This vertical-oriented jet mill system enables us to offer combined operations such as grinding/blending and grinding/coating.

## Flash Drying Services

### THERMAJET

Using our ThermoJet recirculating loop flash dryer technology, we can produce a dry, discrete particle from a filter cake centrifuge or slurry feed. Heat-sensitive materials are dried without degradation due to short residence time and evaporative cooling. Recirculating gases and deagglomeration achieve moisture specifications at less than 0.1%.

## Classification Services (0.5-50 Microns)

### ROTO-SIZER

For precise classification of fine powders, our specially engineered Roto-Sizer produces "cut" sizes down to 3 microns with yields of up to 92%. Our classifier is capable of removing oversize particles from your material. Classification can also remove objectionable fine particles, which can cause downstream process difficulties. Classifying your product can result in substantially increased value at minimal processing cost.

## Fine Powder Processing Expertise

**We can meet all your size reduction requirements from 0.5 microns to 10 mesh**

For more than 50 years, customers representing diverse industries have counted on Fluid Energy to have both the experience and the equipment to fulfill all their fine material processing needs. Today, the Fluid Energy name continues to stand for exceptional quality assurance, responsive service and unmatched expertise in selecting the right grinding technology to match your specific application requirements in the most economical manner.

With full-service capabilities that range from food grade to pre-crushing through ultra-fine particle grinding, classifying, drying, blending, coating, repackaging and heat sealing, Fluid Energy has what it takes to handle any toll grinding challenge. The company specializes in ultra-fine particle reduction of specialty chemicals, minerals, and polymers. Typical lot sizes range from 2,000 lbs. to truck-load quantities. Fluid Energy maintains a laboratory for testing and producing small-scale batch requirements.

Fluid Energy is uniquely equipped to meet the most critical processing deadlines including Just-In-Time inventories. With more than 20 stations, we can turn around any order quickly with little lead time.

Finally, with a division that designs and manufactures jet milling, classifying and flash drying equipment, Fluid Energy is uniquely able to transition customers smoothly from product development to toll manufacturing to in-house manufacturing, without interruptions in production.

### **The versatility to match the right technology for every application**

With a wide range of capabilities in jet milling, drying and classifying, Fluid Energy is uniquely able to process fine materials to your exact specifications, no matter how demanding they may be. Fluid Energy has the capacity to meet every processing application, no matter how many steps may be involved in taking your product from raw feed to finished product. Whether the process requires crushing, drying, or classifying out fines, we can handle it. Fluid Energy is your single-source supplier because we maintain complete in-house responsibility for the processing and packing of your product.

## Ultra-Fine Grinding Services (0.5-50 Microns)

**The widest array of ultra-fine grinding technology in the industry**

The process engineers at Fluid Energy recognize that no one jet mill is suitable for all process applications. We therefore employ three jet mill designs, each with its own unique processing characteristics.



With more than 20 processing stations and 10,000 HP compressed air capacity, Fluid Energy is one of the largest ultra-fine powder processing facilities in the world.



Micro-Jet work station with valve bag packaging. Each work station is designed for maximum flexibility in milling and packaging equipment.

## ISO Certification

Fluid Energy Processing understands that when entering into a toll processing contract, your utmost concern is that quality and documentation are in accordance with your own internal procedures. This dynamic certification ensures maximum quality control and quality assurance that your material is processed and handled within your strict requirements.

## Quality Control

Fluid Energy Processing's quality control department ensures that particle size specifications are strictly controlled and documented. QC personnel are also responsible for ensuring that all product is processed within specifications of the order, including particle size, packaging, labeling and sample generation.

*As one of the  
world's largest  
ultra-fine powder  
processing  
facilities, we  
can handle all  
the fine details  
for you.*

## COMPANY PROFILE

Since 1955, *Fluid Energy Processing & Equipment Company* has specialized in the design and manufacture of ultra-fine grinding and flash drying systems, as well as contract manufacturing of fine and dry powders. With customers around the globe, Fluid Energy has sold more grinding systems than anyone else in the business and operates one of the largest fine grinding processing facilities in the world.

Fluid Energy's Capital Equipment Division offers vertical and horizontal jet-mills, as well as a fluid-bed design with dynamic classification. An ultra-fine classifier is offered to provide precise classification of fine products. In addition, the product line is complimented by a series of flash dryers that dry and de-agglomerate wet solids into fine discrete particle sizes.

Specializing in the production and handling of ultra-fine particles, the company brings a wealth of knowledge to their customers. Vigorous product development efforts, supported by over 50 years experience, have made Fluid Energy the leader in the industry. Through its combined strengths, the company is positioned with the unique ability to integrate their powder processing equipment with highly engineered systems and services. All testing, engineering, and manufacturing services occur within our Eastern Pennsylvania facilities.

Today, Fluid Energy remains the only supplier in the industry that can offer a full range of ultra-fine grinding mills and classifiers – complimented by a versatile series of flash drying systems.

Please call us today to find out how we can optimize your process.

### Equipment and Processing Sales Division

4300 Bethlehem Pike

Telford, PA 18969

Phone: 215-721-8990

Fax: 215-721-2355

Email: [sales@fluidenergype.com](mailto:sales@fluidenergype.com)

### Processing Plant

Hatfield, PA 19440

Phone: 215-368-2510

Fax: 215-368-6235

[www.fluidenergype.com](http://www.fluidenergype.com)

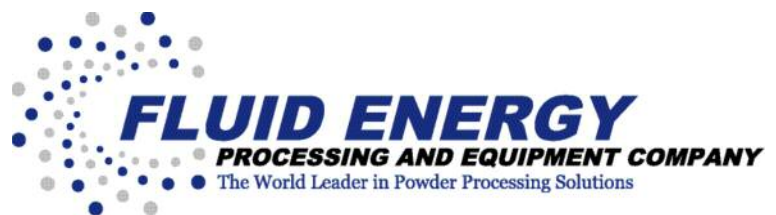

A1863  ISO9001 Registered Firm

*Fluid Energy Processing has  
worked hard to earn and main-  
tain  
registration by*